

Remove the motor. The windlass gearbox has oil inside which must be removed before removing the motor. Older windlasses, windlasses with 3 bolt motors and horizontal windlasses do not have a drain plug. Vertical windlasses have a pipe plug on the side of the gearbox. Horizontals have a pipe plug in the front. Use a small oil-changing pump to remove the oil. Newer vertical windlasses have a drain plug on the bottom surface of the gearbox. See below. Before removing any wires either label them or draw a diagram showing the correct connections. When removing the wires from the motor be sure to hold the check nut in place while loosening the top nut. **Failure to do this may ruin the motor.** See below. Windlasses motors with a square flange have four bolts holding them to the gearbox. Remove the four bolts and pull the motor straight out. The motor has gasket sealant and you may have to break the seal by wiggling the rear end of the motor. Once the bolts are removed and the seal broken the motor will slide straight out. Windlass motors with a flange shaped somewhat like an old fashioned key hole have three bolts, one bolt going through the square end in one direction and the other two bolts 120 degrees apart going in the opposite direction.

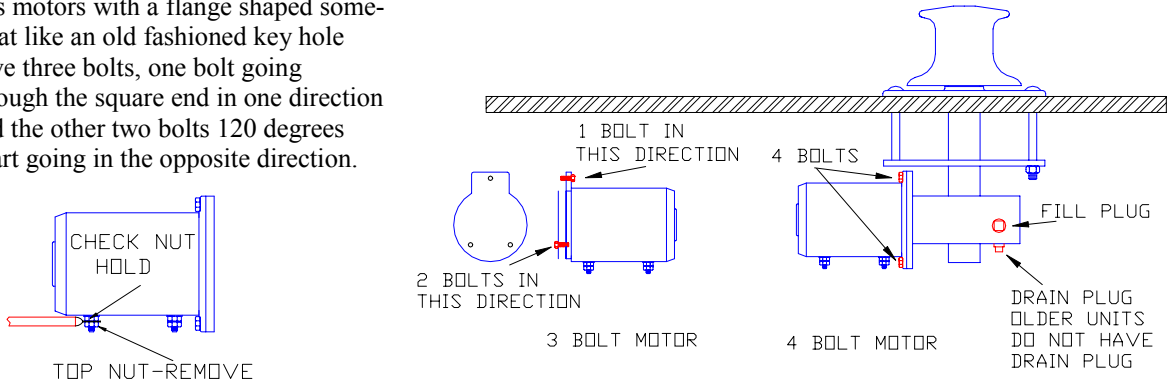

Replacing the motor. Replacement motors are available for all windlasses in all voltages. Motors are sold in two configurations. Complete with gear and bearing ready to bolt to the windlass gearbox. And without the gear and bearing utilizing the original parts. See below. If the old parts are worn, or if there is rust on the motor worm gear they should be replaced. A rusty motor worm gear will act like a file ruining the expensive bronze gear it mates with. AC motors are only available complete with gear & bearing. Motor gaskets. 4 bolt motors use a fiber gasket along with permatex form a gasket. A gasket is provided with each motor. 3 bolt motors do not use a fiber gasket, only per-

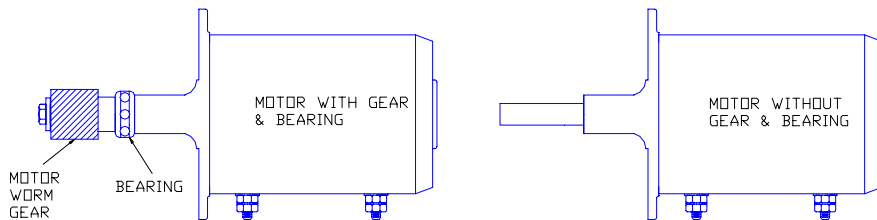

matex form a gasket. When replacing motors all surfaces should be well cleaned before applying permatex and re-assembling.

Refilling the gearbox with oil. All our windlasses use 90 WT gear oil. The oil used in the lower unit of outboard motors works well and is readily available. The proper level is up to the pipe plug fill hole. These are located on the side of the vertical gearboxes and the front of the horizontal gearboxes.

Reattaching electrical connections. Consult your labels or drawing. Be sure to hold the check nut in place while tightening the top nut. See previous page. Below are 2 of the most common 12 volt diagrams.

