

**INSTALLATION
OPERATION &
MAINTENANCE
INSTRUCTIONS**

**IDEAL WINDLASS Co., INC.
5810 POST RD.-P.O. Box 430
E. GREENWICH, RI 02818 USA
401-884-2550 401-884-1260 FAX**

**M
O
D
E
L
V
I
C**

CONTENTS	Installation instructions.....	3-5
	Parts drawing & list.....	6-7
	Wire size & connections.....	8
	Operation & Maintenance.....	9
	Warnings.....	10
	Warranty.....	11

PACKING LIST

Windlass
 Capstan wrench
 Footswitch
 Solenoid
 Instructions tube of oil oil plug
 Circuit breaker panel

TOOLS AND MATERIALS REQUIRED

2-3/4" hole saw
 7/16" drill bit
 electric drill
 wrench set
 slotted screwdriver
 caulking gun
 caulking
 wire
 wire connectors
 light grease
 patience

SERIAL NUMBER

For future reference please register the serial number and voltage found on the windlass nameplate below.

Ser.# _____ Voltage _____

Windlasses designed and manufactured in the USA.

Location: The location of the windlass must be given considerable thought. Keep in mind the following: The chain must approach the wildcat at a 90 degree angle to the main shaft, the chain stopper must be installed keeping with the place of the incoming chain, and the total wrap of chain around the windlass must be as shown on the diagram below. The rotation of the windlass when pulling in the anchor must be clockwise. Also, there must be enough room below the deck for the windlass gear case and motor and the chain locker pipe must be installed so that the chain drops into a deep part of the chain locker.

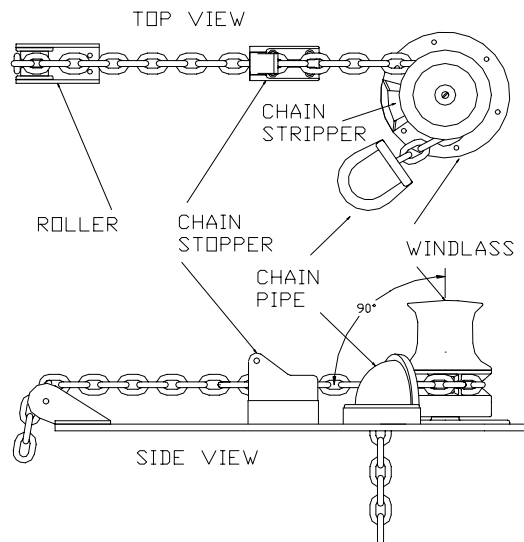

1. Refer to the enclosed parts drawing and remove the following:
PC#s 2-10 & 19-21
2. Remount the chain stripper (PC#19) to the deck plate, (PC#10).
3. Place the deck plate with the chain stripper on the deck in the desired location. Make sure there is enough room below for the gear case assembly and that the chain stripper is in the proper location. (See above).
4. Place the chain locker pipe as close to the windlass as possible. Make sure that the vertical drop of chain into the locker is longer than the distance the chain has to travel across the deck to the pipe. It is the weight of the vertical chain that will drag the chain leaving the windlass into the locker. Improper placement of the chain locker pipe will cause the chain to pile up on deck.

INSTALLATION

5. Mark the location of the chain locker pipe and the deck plate. Mark the location of the mounting bolt holes keeping in mind the position of the assembly below deck. Make sure that the motor will be away from the chain coming through the deck.

6. Once you are certain everything will be in its proper place, drill the 3 mounting bolt holes using a 7/16" drill bit. Drill the center hole using a 2-3/4" hole saw.

7. If there is deck camber or shear or if the height of the wildcat needs to be raised (see page 3 diagram) you may need to prepare a deck pad 8" in diameter to correct these problems. If you must raise the height of the wildcat keep in mind that **THE TOTAL THICKNESS FROM THE BOTTOM OF THE DECK PLATE TO THE TOP OF THE 3 GEAR CASE MOUNTING FEET MUST BE KEPT AT EXACTLY 4"**! It is this distance which locates the position of the chain stripper (PC#19). If this distance of 4" is not held exactly, the above deck parts will not fit together properly. If your windlass was made with a special deck thickness, substitute that figure for the 4".

8. Take one of the mounting bolts & insert it into the deck plate. Measure from the underside of the deck plate 4" and mark the spot. If your windlass was made with a special deck thickness, substitute that figure for the 4". See below.

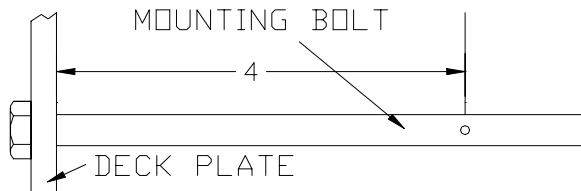

9. With the deck plate and deck pad (if used) in place, insert the marked bolt. Measure from the underside of the deck to the marked spot on the bolt. This will be the required thickness of your below deck spacer. This spacer can be larger than the deck plate to act as a bolster plate but must be made to miss any obstructions.

10. Prepare a spacer of suitable size and drill for the center hole and mounting bolts. It is a good idea to make these holes slightly oversized to ease installation.

11. Use the tube of oil supplied with your windlass to fill the gear case up to the level of the oil plug hole. **DO NOT OVERFILL.** You will not need the entire tube of oil. Save for later

12. Bed the underside of the deck plate with caulking and place in position. Be sure to use caulking that is removable. **DO NOT USE 5200.**

13. Install the gear case and spacer from below deck by carefully pushing the shaft up through the deck plate bearing. Bolt into position with the 3 mounting bolts. Be careful to tighten the bolts evenly to avoid binding the shaft in the deck plate bearing.

14. Remove the chain stripper from the deck plate. Lightly grease the main shaft and the bore of the above deck parts. Don't get ANY grease on the friction discs. Reassemble the above deck parts.

15. Select a suitable location on deck for the footswitch. **CAUTION:** Keep the safety of the operator in mind when locating the switch. It must be located so that the operator can comfortably activate the windlass and tail the incoming line. It must not be placed so close that the operator can accidentally activate the switch with hand on the windlass. Be sure to bed the switch.

16. Wire the windlass as per the wiring diagram on page 8. To insure safe and proper operation, wire with the Proper size wire and be sure this is done by a qualified electrician. **CAUTION:** Be sure to isolate and protect the electrical system.

INSTALLATION

DRAWING & PARTS LIST

ITEM	QTY	PART #	NAME
1	1	MCW-4A	CAPSTAN WRENCH rod
2	1	CS-10	CAPSTAN SCREW
3	1	CW-10	CAPSTAN WASHER
4	1	MCW-4	CAPSTAN CAP
5	1	MCW-1	CAPSTAN
6	1	CK-35	CAPSTAN KEY
7	2	CWM-9	FRICTION DISCS
8	1	CWM-10	WILDCAT
9	1	CWM-8	LOWER FRICTION PLATE
10	1	MM-26	DECK PLATE
11	3	DB-35	DECK BOLTS
12	1	MCW-3	MAIN SHAFT
13	3	NU-35	NUTS
14	1	MM-01	GEAR CASE
15	1	A-20	MOTOR WORM
16	1	AM-12	WORM GEAR
17	2	AM-16	BEARING CAP
18	6	FA-35	SET SCREW
19	1	ADX-3A	CHAIN STRIPPER
20	2	FA-35	CHAIN STRIPPER BOLTS
21	1	DP-35	DRIVE PIN
22	1	BA-35	BALL BUSHING
23	1	OS-35	OIL SEAL
24	1	WK-35	WORM KEY
25	2	SS-35	SET SCREW
26	1	EX-35	EXPANSION PLUG
27	1	CP-35	COTTER PIN
28	1	CN-35	RETANING NUT
29	1	WK-09	MOTOR WORM KEY
30	1	GT-3	THRUST BEARING
31	1	AM-3	END BELL
32	1	SO-12	SOLENOID non reversing
32	1	SO-12REV	SOLENOID reversing
33	1	FSB	FOOTSWITCH complete
34	1	MM-350-12	MOTOR W/OUT GEAR & BRG
34	1	MMC-350-12	MOTOR W/OUT GEAR & BRG
35	1	FSA-1B	RUBBER COVER
36	1	FSA-3	MOUNTING RING
37	2	FSA-7	SWITCH MOUNTING NUTS
38	1	ELM-DC	SWITCH ELEMENT
39	1	FSA-2	MOUNTING PLATE
40	6	FSA-6SS	MOUNTING SCREWS
41	1	MM-26A	BALL CAP
42	3	FA-1032FH	BALL CAP SCREWS
43	1	BS-35	BALL CAP SEALS
44	1	MM-87	MOTOR OIL SEAL

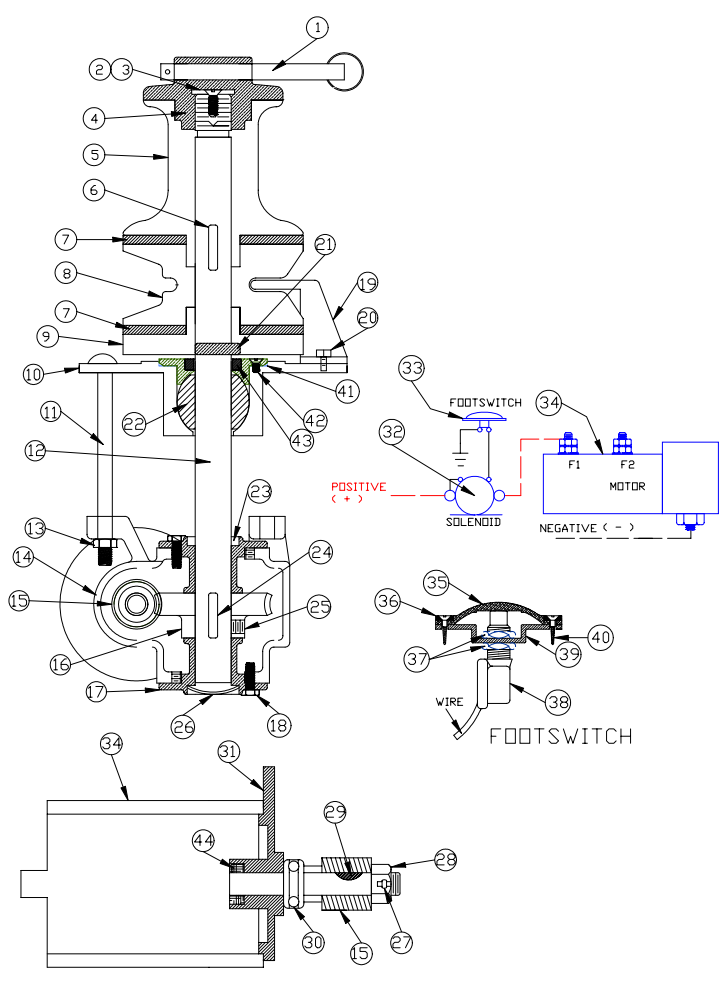

WIRE SIZES & CONNECTIONS

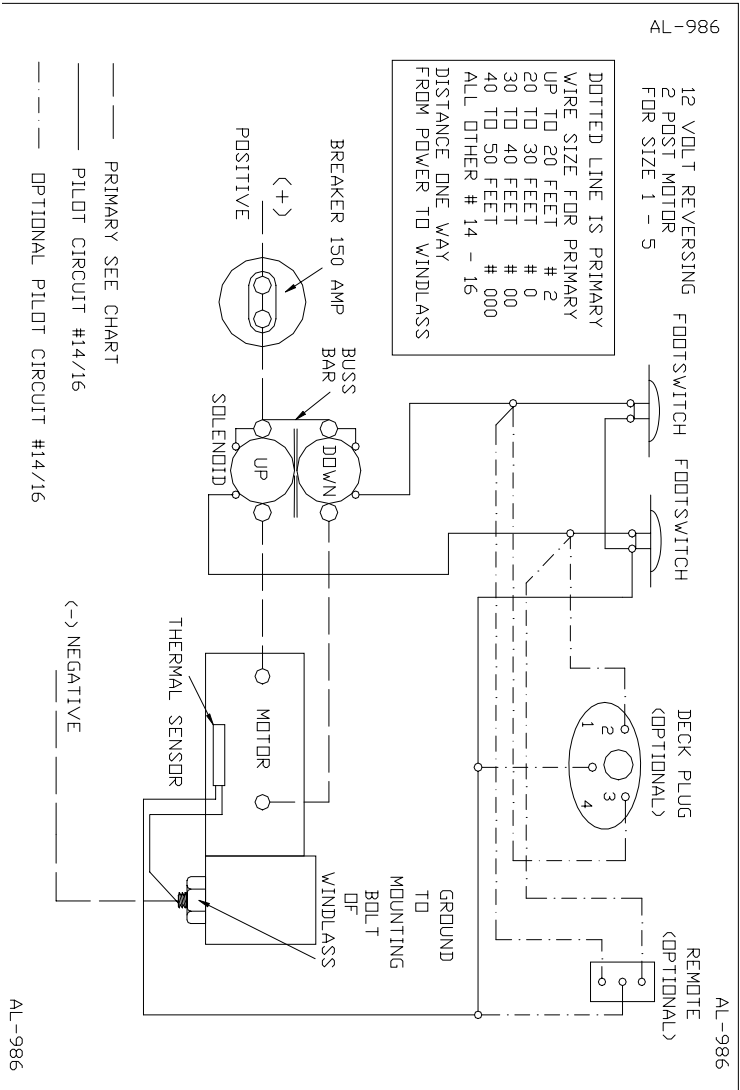

OPERATION

The **capstan** is directly keyed to the main shaft and will always turn when the windlass is engaged. Wrap 3-4 turns around the capstan in a clockwise direction, and while keeping tension on the line, step on the foot switch. If the line slips apply more tension or add another wrap. The capstan may be used independently of the wildcat by loosening the capstan cap with the wrench.

The **wildcat** is not directly keyed to the shaft. It is driven by a friction system. To loosen the wildcat, insert the capstan wrench into the top of the cap and turn in a counter-clockwise direction. This will enable the chain to pay out freely. The speed of the outgoing chain may be controlled by the amount of pressure put on the wildcat with the capstan wrench. To tighten the wildcat, turn the cap in a clockwise direction. If the wildcat continues to slip apply more pressure. See the list of warnings for proper windlass usage.

The windlass electrical system must be isolated and protected. **CIRCUIT BREAKER:** the breaker should be left OFF when the windlass is not in use. This will prevent accidental activation. If the breaker trips from electrical overload it can be reset immediately. If the thermal sensor located on the motor senses too much heat it will deactivate the solenoid and the windlass will not restart until the motor cools down.

MAINTENANCE

Once or twice a season check the oil level in the gear case. The level should be just below the level of the oil plug. Add 90 weight gear oil if necessary.

Once a season remove the above deck parts , clean the bores and lightly grease the shaft. This will enable the parts to be removed if the windlass ever has to be removed from the boat for service. Also check the electrical connections and spray with WD-40 or similar.

The deck plate bearing is self-lubricating and self-aligning. If necessary, access main be gained by removing the three bolts holding down the ball cap cover.

**L
I
S
T

O
F

W
A
R
N
I
N
G
S**

**PAY ATTENTION!!!
READ THESE WARNINGS!!!**

WARNING: The anchor windlass has been designed for the following purposes; raising and lowering the anchor and warping into a dock. **NOT RECOMMENDED** are the following; hoisting crew, towing the vessel, leaving the vessel tied off to the windlass. Such uses can be dangerous and can cause serious injury.

WARNING: DO NOT OPERATE THE WINDLASS WHEN UNDER THE INFLUENCE OF ALCOHOL, DRUGS OR MEDICATION. DOING SO CAN RESULT IN SERIOUS INJURY.

WARNING: Always use extreme caution when using the anchor windlass. All operators must read the operating instructions and be well trained in all aspects of anchoring and anchor hauling. In extreme weather only well trained crew members should be allowed to operate or be in near proximity to the windlass while in use. As with all moving machinery, **extreme care must be exercised to keep all body parts, especially hands and feet, away from the windlass.** Failure to follow these warnings can result in serious injury.

WARNING: The electrical system of the windlass must be isolated and protected. The power to the windlass should be left off until the windlass is needed.

WARNING: Do not allow the windlass to operate without a load for any length of time. Severe damage to the motor will result.

The Ideal Windlass Company (“Ideal”) warrants to the original consumer purchaser of this product, that it is free from defects in materials and workmanship. Ideal’s responsibility is limited to repair or, at Ideal’s election, replacment of any defective product and does not include any charges for removal, reinstallation, or incidental or consequential damages. Some states do not allow the exclusion or limitation of incidental or consequential damages, so the above limitation or exclusion may not apply to you.

EXPIRATION:This warranty and any implied warranties shall expire two (2) years from the date of purchase. Some states do not allow limitations on how long an implied warranty lasts, so the above limitations may not apply to you.

EXCEPTIONS:The above warranty does not apply to: metal finishes or coatings, a product not installed or maintained following Ideal’s instructions, damaged by casualty or improper use, repaired or modified by other than Ideal personnel, installed in a vessel or manner judged by Ideal to be an inappropriate application of its product, or used with other products incompatible with the Ideal product or which adversely affect its performance or durability.

CLAIM PROCEDURE:

- (1) Immediately upon discovery of any apparent defect notify your vendor, boat builder or Ideal describing such defect;
- (2) the vendor, boat builder or Ideal shall make a preliminary determination as to whether a warranty claim is justified and if so,
- (3) upon request, Ideal shall authorize return or repair of the product.

NO PRODUCT SHALL BE RETURNED UNTIL AUTHORIZED BY IDEAL.

- (4). After such authorization, return the product, freight prepaid, with proof of purchase, and serial number to Ideal Windlass Co., 5810 Post Rd., E. Greenwich, RI 02818 USA.
- (5) If found defective, Ideal will repair or replace the product.

OTHER RIGHTS: This warranty gives you specific legal rights and you may have other rights which vary from state to state.

**W
A
R
R
A
N
T
Y**

