

CONSIDERING ADDING A WILDCAT TO YOUR ROPE ONLY CAPSTAN?

Being able to handle chain with your windlass greatly enhances your anchoring options. Anchoring with an all chain anchor rode makes anchoring a lot safer & easier. See our brochure on anchoring with all chain for details. Rebuilding your existing windlass has several advantages. First, you have a substantial, well built windlass, why replace it? Second, rebuilding the windlass eliminates any costly modifications to the deck area as the windlass will reinstall in the same holes and bolt pattern. Third, the existing wiring can stay the same, although you may wish to add a reversing kit, which changes a small portion of the wiring at the windlass. Last, rebuilding is usually quite cost effective as opposed to replacing.

We can provide detailed instructions on how to get the windlass out of the boat. You can ship the windlass to the address below and we will provide an estimate and the different options. The process usually takes 2 to 4 weeks. In the end you will have a windlass and anchoring system that works well, will last a long time, and will enhance your boating experience.

To CONVERT a rope only capstan to handle chain a wildcat must be added. To do this the windlass must be removed from the boat & rebuilt with a new, longer shaft and several other new parts. The conversion kit includes these parts as well as bushings, gaskets etc. that would normally be replaced. The kit does not include repair parts such as gears or motors.

A CHAIN PIPE or hawser will be necessary to direct the chain into the locker. These chain pipes and chain stoppers are not included in the kits. See our arrangement drawing for placement of chain pipes & stoppers.

OTHER OPTIONS include reversing kits, remote control panels & wireless remotes.

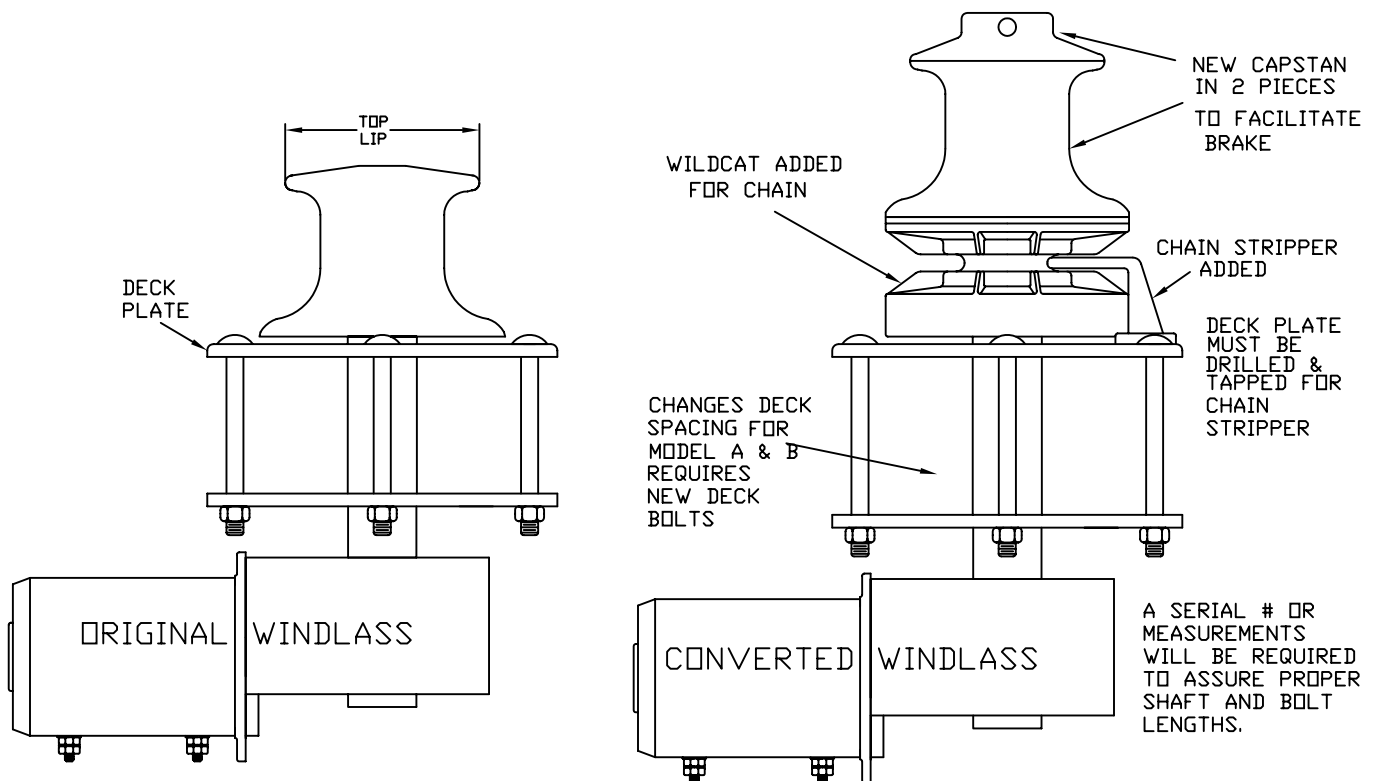

TOP LIP	PLATE DIAMETER	# OF BOLTS	MODEL	CONVERTS TO	STANDARD DECK SPACE	CHANGES TO
3 7/8"	7 1/4"	3	MM or V1A	MCW	4	4
5 3/4"	10 3/8"	4	A or V3A	ACW	4	4 5/8"
6 5/8"	11	4	B or V5A	BACW	4 1/2"	5 1/2"